

Safety Breakaway Switch No. 1100-42

P-1377
819-0090

Installation Instructions

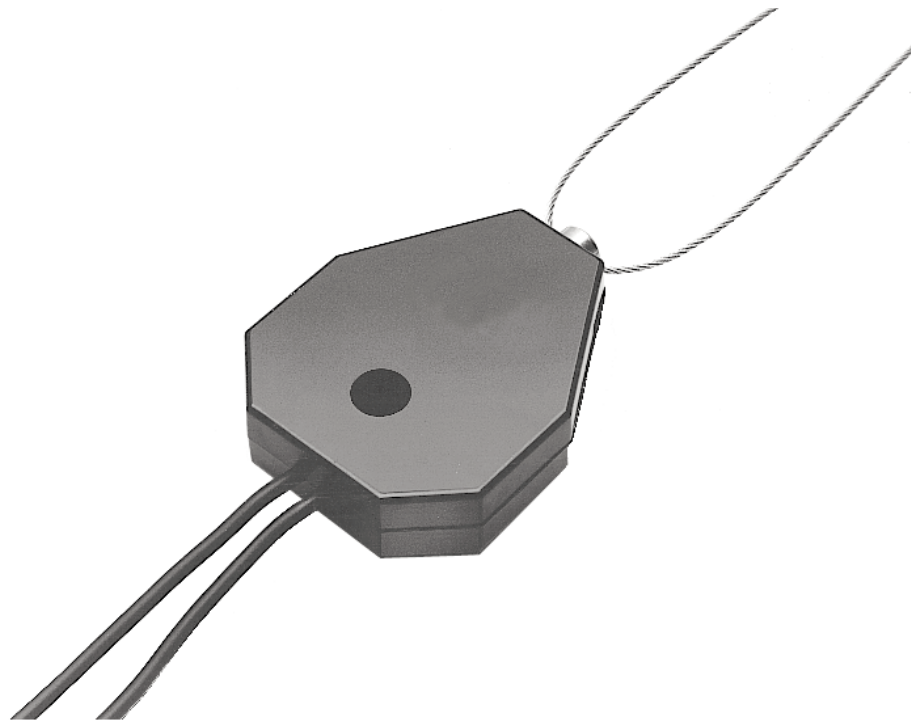

Parts Included in Kit

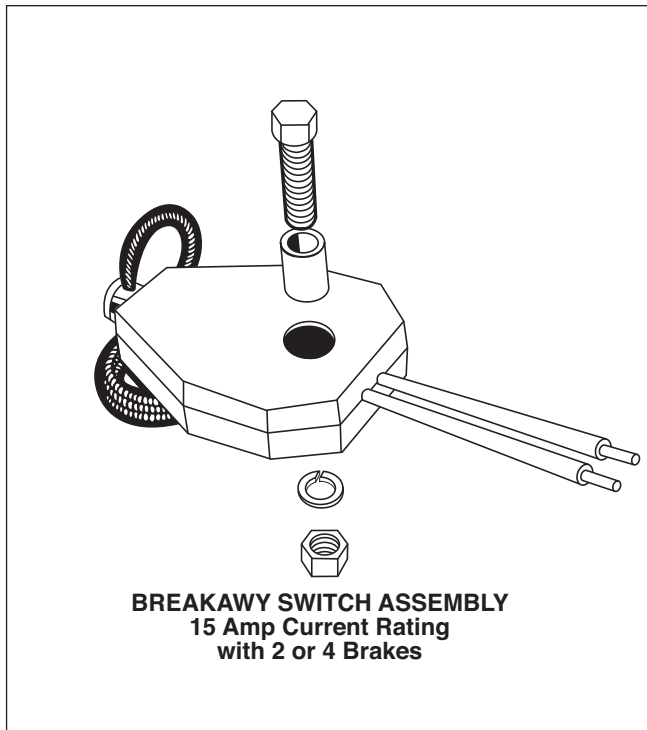

Activated only in the event of a trailer breakaway emergency, the breakaway switch remotely activates the independent safety circuit of the trailer brake systems. Sonic welded case protects electrical component against water and sun.

Recommended for recreational and light commercial trailers. 12V. Up to four brake capacity. Not polarity sensitive, + or - ground.

Consists of:
 1 - Breakaway Switch
 1 - Mounting Accessory
 1 - Installation Instruction

Cable & Pin Assembly
 1100-253-002

⚠ WARNING Failure to follow these instructions may result in product damage, equipment damage, and serious or fatal injury to personnel.

Typical Installation

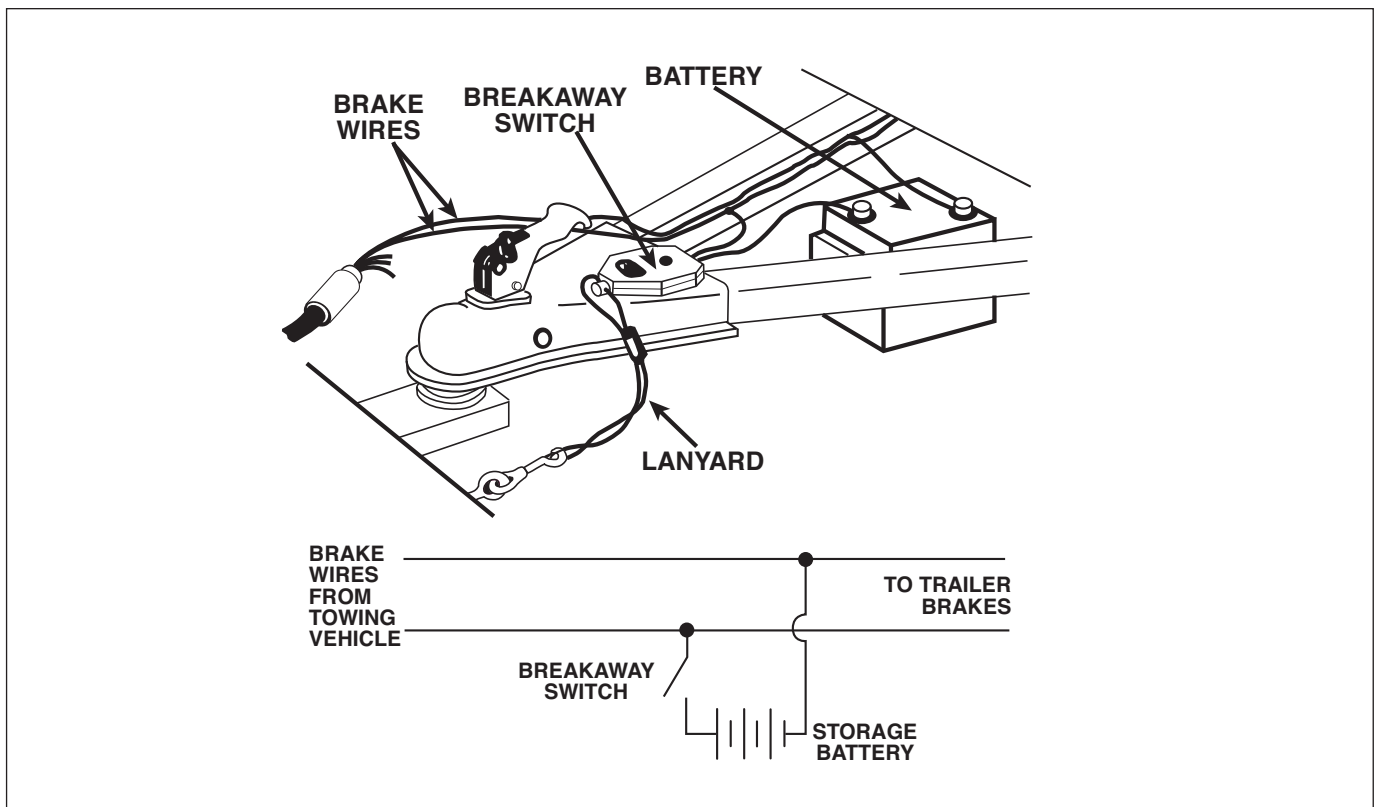

Installation Instructions for Warner Safety Breakaway Switch

15 Amp Current Rating with 2 or 4 Brakes Part Number 1100-42

The purpose of the Safety Breakaway Switch is to minimize the possibility of an accident due to a “runaway” trailer. If a trailer becomes detached from the towing vehicle during transit, the switch pin is pulled out by the lanyard. This closes the circuit connecting the battery to the trailer brakes, providing electricity to stop the trailer.

1. Position the breakaway switch on the trailer frame with the pin pointing toward the towing vehicle. Allow sufficient lanyard length to attach the lanyard to the towing vehicle. The lanyard should be long enough to allow for turning corners, yet short enough to disengage the pin from the switch before the safety chains on the hitch become taut in a trailer disconnect situation.
2. Position the Warner Safety Breakaway Switch on any horizontal surface of the tongue so the lanyard cable and breakaway switch have no forward obstructions and can swivel freely. Drill a 9/32" hole for the attachment of the switch. Insert the metal sleeve furnished into the mounting hole in the switch and mount the switch on the tongue using the bolt, nut, and lockwasher provided. The sleeve will allow the switch to pivot freely, assuring alignment of the lanyard with the towing vehicle.

3. Mount a battery on the trailer frame. The battery must be the same voltage as the trailer brakes and have adequate capacity to meet legal requirements of the states in which the trailer will be towed.

Note: An automotive-type storage battery is preferred as the power source.

4. Connect one lead from the switch to one of the battery terminals. Connect the other battery terminal to one of the trailer brake supply wires, matching the tow vehicle polarity. Connect the other lead from the switch to the remaining brake wire, leaving enough slack for the switch to swivel (see illustration). Make sure all terminals and connections are secure and well insulated.
5. Fasten the lanyard to a convenient structural member of the towing vehicle. Do not fasten it to the hitch assembly. A snap hook and eyebolt can be added to facilitate hookup and removal of the lanyard.

▲CAUTION The system should be tested periodically by pulling the pin and trying to pull the trailer with the towing vehicle. The trailer brakes should be engaged. After testing, return the pin to the “full-in” position. Avoid prolonged or frequent activation of the safety switch, since the battery is discharged whenever the switch is actuated. Check the battery periodically with a hydrometer or other suitable battery tester to assure that full charge is maintained in accordance with the battery manufacturer’s recommendations.

Warranty

Warner Electric LLC warrants that it will repair or replace (whichever it deems advisable) any product manufactured and sold by it which proves to be defective in material or workmanship within a period of one (1) year from the date of original purchase for consumer, commercial or industrial use.

This warranty extends only to the original purchaser and is not transferable or assignable without Warner Electric LLC's prior consent.

Warranty service can be obtained in the U.S.A. by returning any defective product, transportation charges prepaid, to the appropriate Warner Electric LLC factory. Additional warranty information may be obtained by writing the Customer Satisfaction Department, Warner Electric LLC, 449 Gardner Street, South Beloit, Illinois 61080, or by calling 815-389-3771.

A purchase receipt or other proof of original purchase will be required before warranty service is rendered. If found defective under the terms of this warranty, repair or replacement will be made, without charge, together with a refund for transportation costs. If found not to be defective, you will be notified and, with your consent, the item will be repaired or replaced and returned to you at your expense.

This warranty covers normal use and does not cover damage or defect which results from alteration, accident, neglect, or improper installation, operation, or maintenance.

Some states do not allow limitation on how long an implied warranty lasts, so the above limitation may not apply to you.

Warner Electric LLC's obligation under this warranty is limited to the repair or replacement of the defective product and in no event shall Warner Electric LLC be liable for consequential, indirect, or incidental damages of any kind incurred by reason of the manufacture, sale or use of any defective product. Warner Electric LLC neither assumes nor authorizes any other person to give any other warranty or to assume any other obligation or liability on its behalf.

WITH RESPECT TO CONSUMER USE OF THE PRODUCT, ANY IMPLIED WARRANTIES WHICH THE CONSUMER MAY HAVE ARE LIMITED IN DURATION TO ONE YEAR FROM THE DATE OF ORIGINAL CONSUMER PURCHASE. WITH RESPECT TO COMMERCIAL AND INDUSTRIAL USES OF THE PRODUCT, THE FOREGOING WARRANTY IS IN LIEU OF AND EXCLUDES ALL OTHER WARRANTIES, WHETHER EXPRESSED OR IMPLIED BY OPERATION OF LAW OR OTHERWISE, INCLUDING, BUT NOT LIMITED TO, ANY IMPLIED WARRANTIES OF MERCHANTABILITY OR FITNESS.

Some states do not allow the exclusion or limitation of incidental or consequential damages, so the above limitation or exclusion may not apply to you. This warranty gives you specific legal rights and you may also have other rights which vary from state to state.

Changes in Dimensions and Specifications

All dimensions and specifications shown in Warner Electric catalogs are subject to change without notice. Weights do not include weight of boxing for shipment. Certified prints will be furnished without charge on request to Warner Electric.



Warner Electric LLC
449 Gardner Street • South Beloit, IL 61080
815-389-3771 • Fax: 815-389-2582
www.warnerelectric.com
An Altra Industrial Motion Company